

DIN 6916

ÇELİK KONSTRUKSİYON PULU PLAIN WASHERS FOR STEEL CONSTRUCTION FLACHE UNTERLEGSCHIEBE FÜR STAHLKONSTRUKTIONEN

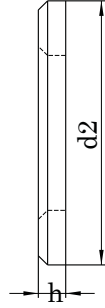
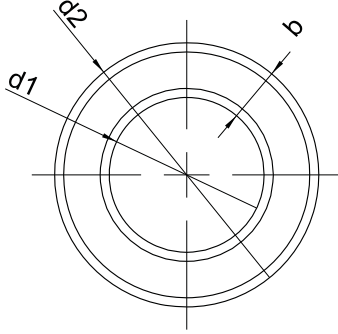

Technical Informations / Teknik Bilgiler

Thread size / Anma çapı (d)		M12	M16	M20	M22	M24	M27	M30	M36
d_1	min.	13,00	17,00	21,00	23,00	25,00	28,00	31,00	37,00
	max.	13,27	17,27	21,33	23,33	25,33	28,52	31,62	37,62
r	min.	23,48	29,48	36,38	38,38	43,38	49,00	54,80	64,80
	max.	24,00	30,00	37,00	39,00	44,00	50,00	56,00	66,00
h	min.	2,70	3,70	3,70	3,70	3,70	4,40	4,40	5,40
	max.	3,30	4,30	4,30	4,30	4,30	5,60	5,60	6,60
gr/p		7,03	14,60	19,60	24,30	30,60	50,20	63,20	115,00
Vickers (HV)									295 - 350 HV.

Values are given in millimeters. / Değerler milimetre olarak verilmiştir.