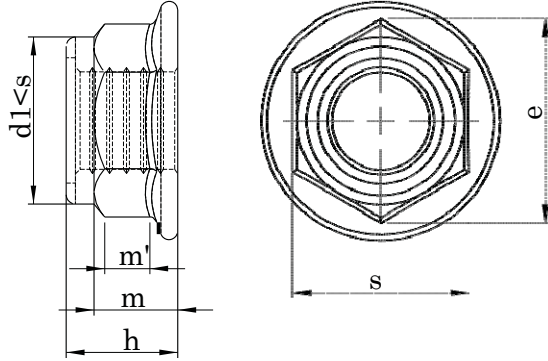

DIN 6926 ISO 7043**FİBERLİ FLANŞLI ALTİKÖŞE SOMUNLAR****PREVALING TORQUE TYPE HEXAGON NUTS WITH FLANGE AND WITH NON-METALLIC INSERT****SECHSKANTMUTTER MIT KLEMMTEIL UND FLANSCH (MIT NICHTMETALLISCHEM EINSATZ)****Technical Informations / Teknik Bilgiler**

Thread size / Anma çapı (d)			M6	M8	M10	M12	
Pitch / Diş adımı	c	p1 min.		M8 X 1,00	M10 X 1,25	M12 X 1,5	
		p2 max.			M10 X 1,00	M12 X 1,25	
		p3	1,00	1,25	1,50	1,75	
Diagonal / Köşegen	d _a	min.	1,10	1,20	1,50	1,80	
		max.	6,75	8,75	10,80	13,00	
	d _c	min.	6,00	8,00	10,00	12,00	
		max.	14,20	17,90	21,80	26,00	
	d _w	min.	12,20	15,80	19,60	23,80	
	e	min.	11,05	14,38	16,64	20,03	
Height / Yükseklik	h	min.	9,10	11,10	13,50	16,10	
		max.	8,74	10,67	13,07	15,67	
		m	min.	5,70	7,60	9,60	11,60
Head width / Anahtar ağızı	s	m'	min.	3,10	4,50	5,50	6,70
		nom.=max.	10,00	13,00	15,00	18,00	
		min.	9,78	12,73	14,73	17,73	
Weight / Ağırlık	gr/p	r	max.	0,36	0,48	0,60	0,72
				4,28	8,72	13,80	24,64

Values are given in millimeters. / Değerler milimetre olarak verilmiştir.